

AGENDA
CITY OF TAYLOR, TEXAS
PUBLIC ARTS ADVISORY BOARD MEETING
CITY HALL CONFERENCE ROOM, 400 PORTER STREET, TAYLOR, TX 76574
APRIL 22, 2026, 5:30 PM

I. CALL TO ORDER AND DECLARE A QUORUM

II. CITIZEN COMMUNICATION

(The Board or Commission welcomes public comment on items not listed on the agenda. However, the Board or Commission cannot respond until the item is posted on a future agenda. All public comments are limited to 3 minutes.)

III. CONSENT AGENDA

1. Provide approval for May 25, 2026 Public Arts Advisory Board Minutes

IV. REGULAR AGENDA - NEW BUSINESS

2. Consider and take potential action on creating a "Public Art of Taylor Map" *Ruby Fisher*

V. REGULAR AGENDA - CONTINUING BUSINESS

3. Consider and take potential action on the Painted Piano Project.
4. Consider and take potential action on the Heritage Square Signature Art Project
5. Receive update and take potential action from Music on Main Committee.

VI. ADJOURN

The Board or Commission may vote and/or act upon each of the items listed in this Agenda. The Board or Commission reserves the right to retire into executive session concerning any of the items listed on this Agenda, whenever it is considered necessary and legally justified under the Open Meetings Act, I certify that the notice of meeting was posted in the Taylor City Hall Lobby before 5:00 pm on April 16, 2026 and remained posted for at least three business days before the scheduled date of said meeting.

Ruby Fisher

Date: April 16, 2026

Special Events Coordinator, City of Taylor

MINUTES

CITY OF TAYLOR, TEXAS

PUBLIC ARTS ADVISORY BOARD MEETING

City Hall – Council Chambers 400 Porter Street, Taylor, Texas 76574

February 25, 2026, 5:30 p.m.

MEMBERS PRESENT

Bryan Richie
Gail Samuels
Betsy Askew
Cindy Chapter

MEMBERS ABSENT

Monica Zavala
Nicolas Nadeau

OTHERS PRESENT

Ruby Fisher, City Liaison
Greg Redden,
Councilmember
Daniel Seguin, Executive
Director of Community
Services
Carrie D’Anna
Pamela Griffin
Richard Stone
Leslie Hill

I. CALL TO ORDER AND DECLARE A QUORUM

A quorum was declared and the meeting was called to order at 5:33 pm.

II. CITIZEN COMMUNICATION

III. CONSENT AGENDA

1. Approve minutes from the February 25, 2026 meeting of the Public Arts Advisory Board

A motion as made to approve the minutes by Cindy Chapter, seconded by Bryan Richie – the motion passed unanimously.

IV. REGULAR AGENDA - NEW BUSINESS

2. Discuss and take action on the appointment of the Chair position

A motion was made by Byran Richie for Bryan Richie to serve as the Chair of the Public Arts Advisory Board, and seconded by Cindy Chapter. The motion passed unanimously.

3. Discuss and take action on the appointment of the Vice-Chair position

A motion was made by Gail Samuels to nominate Cindy Chapter to serve as vice-chair of the Public Arts Advisory Board, the motion was seconded by Bryan Richie. The motion passed unanimously.

V. REGULAR AGENDA - CONTINUING BUSINESS

4. Consider and take potential action on the Painted Piano Project proposal.

A motion was made by Betsy Askew to recommend for approval the Painted Piano Project, seconded by Cindy Chapter and passed unanimously.

5. Consider and take potential action on the Heritage Square Signature Art Project

A motion was made by Gail Samuels and seconded by Betsy Askew to recommend the Heritage Square Signature Art Project for approval.

6. Receive an update on Robinson Park Portals - Texas Geocaching Association Murals

Mrs. Leslie Hill noted that she has lived in Taylor for all of her life. Mrs. Hill noted that she was requesting for the murals to be removed – she wants something that better represents the town and is a more complete celebration. Mrs. Hill noted that there was a history of Taylor that was ignored, that Robinson Park used to be Friendship Park – where everyone was welcome.

Carrie D’Anna highlighted that the Dickey-Givens Community Center functions differently than the previous Community Center. That it is not as accessible because of its price and how frequently it is booked out. That it was shocking for the community to see the murals being put there.

Pamela Griffin highlighted that the murals were like getting your house painted a color and not getting to pick. That the murals were done by outsiders was very detrimental.

Carrie D’Anna noted that the event was cool – because her kids were introduced to geocaching. Carrie D’Anna wants to reiterate the experiences of Pamela Griffin and Leslie Hill. D’Anna said that the community needed things done with them, not for them. D’Anna highlighted the intent was good – but the impact was great. D’Anna said that the greater impact of the lack of communication was hurtful. D’Anna said if this is their park and their community that the murals should have been done with them, not for them.

7. Receive update and take potential action from Music on Main Committee.

Bryan Richie reported that Music on Main had a great turnout and the folks bought enough food to sell out multiple food vendors. 300-400 folks were present in the crowd.

VI. ADJOURN –

A motion was made by Cindy Chapter and seconded by Gail Sammuels, the motion passed unanimously. The board adjourned at 6:38 pm.

VI. ADJOURN



Taylor Public Arts

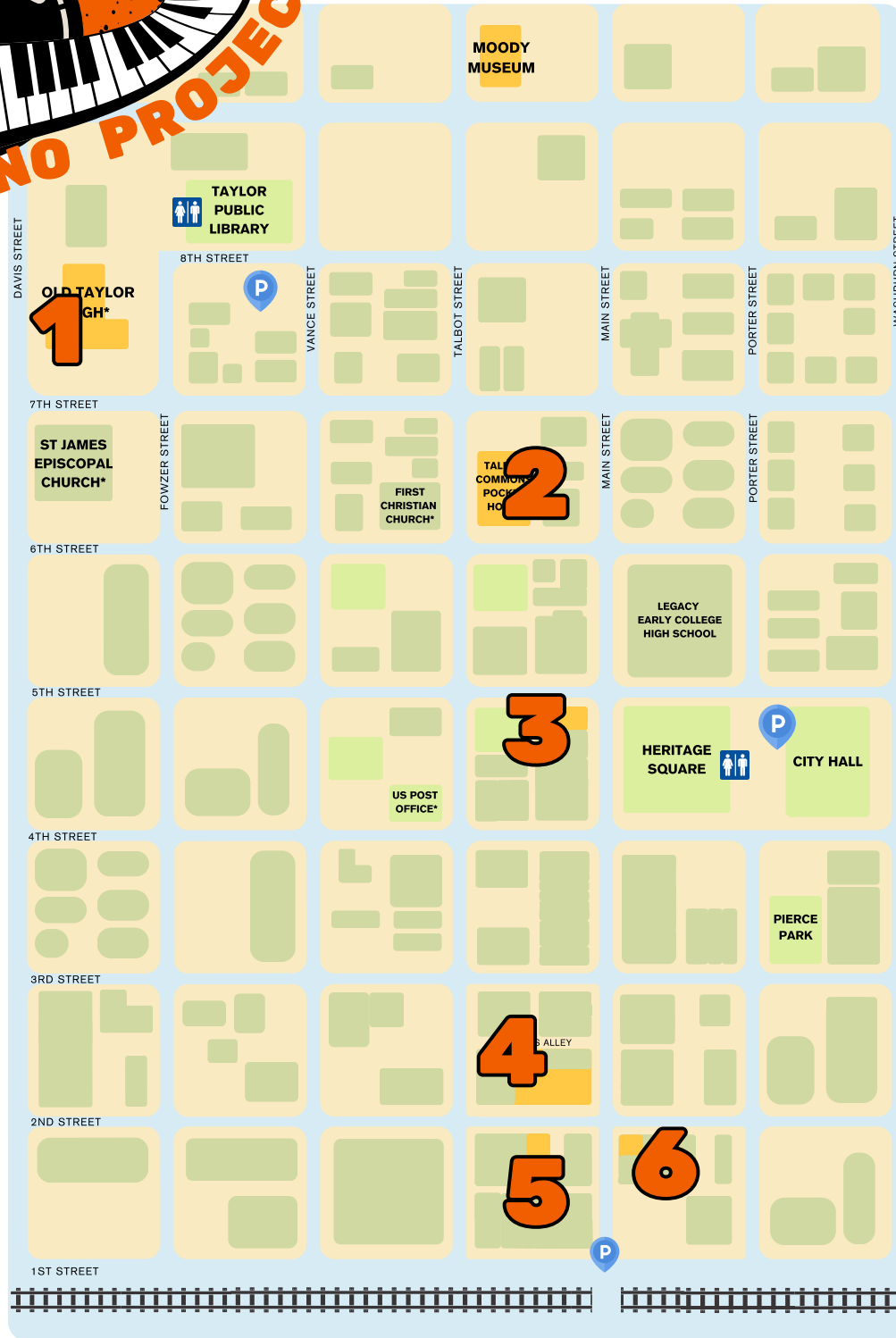

- 1. Old Taylor High - HOT Tax Funded
- 2. Talbot Commons Pocket Hotel - Privately Funded
- 3. Karch Music - TIF Funded
- 4. McCrory Timmerman - TIF Funded

- 5. Black Sparrow Music Parlor - TIF Funded
- 6. 2nd and Main Building - TIF Funded
- 7. Percussion Park - HOT Tax Funded and Non-profit Funded

Taylor Public Arts

BUDGET/Funding Sources

- \$750.00/artist * 7 pianos - \$5250.00
- \$175 for tuning - \$1,225
- Piano Dolly Materials?
- Locks - \$140
- Hasps - \$70
- Marketing - \$300
- Front Porch Party - Piano Release: \$1,000.00

Total Cost: \$8,500

- TIF Fund for Public Art: \$6,650.00
- HOT Tax Request: \$1,850.00

IMPLEMENTATION TIMELINE

Painted Piano Project Implementation Timeline (Post-Council Approval)

Week 0 – Council Approval

- Formal approval granted
- Budget and scope confirmed
- Internal project lead assigned
- Finalize project guidelines

Weeks 1–2 – Artist Call & Promotion

- Release Call for Artists
- Promote through city channels, social media, and local arts networks
- Conduct outreach to schools, artists, and community groups

Weeks 3–7 – Application Period

- Accept submissions (typically 2–3 weeks)
- Respond to inquiries and provide clarifications
- Begin preliminary review as applications are received

Week 7 – Selection Process

- Convene selection committee
- Review and score submissions
- Notify selected artists and alternates

Weeks 8–9 – Logistics & Preparation

- Procure or accept donated pianos
- Coordinate piano tuning and minor repairs (if needed)
- Distribute stipends to artists
- Finalize installation plan and site permissions



Weeks 10–12 – Painting Phase

- Artists paint pianos (on-site or designated workspace)
- Monitor progress and ensure adherence to guidelines

Week 13 – Installation

- Transport and secure pianos at designated locations
- Install signage (artist credit, project info, rules for use)
- Final inspection for safety and quality

Week 14 – Launch & Activation

- Host Porch Piano Release Party
- Promote via press release and social media
- Encourage community engagement (photos, performances, etc.)

Ongoing – Maintenance & Program Management

- Routine inspections and touch-ups as needed
- Monitor for vandalism or weather damage
- Plan for seasonal rotation or long-term storage if applicable
- Ensure Painted Piano Locations are on directory guide

Optional (6–12 Months Post-Launch) – Program Evaluation

- Gather community feedback
- Assess impact and participation
- Determine continuation, expansion, or improvements

Taylor Public Arts Painted Piano Project



We're looking for creative minds to transform pianos into public works of art! Your design could bring music, color, and joy to Taylor's public spaces.

Make your mark in historic downtown Taylor!

Let your art be heard and seen!



Taylor Public Arts

Artist Application



The City of Taylor invites artists to participate in the Painted Piano Project, a public art initiative designed to bring creativity, culture, and community engagement to the downtown district. Selected artists will transform donated pianos into vibrant, functional works of art that reflect the spirit and identity of Taylor. Completed pianos will be installed throughout the community in August 2026, culminating in a public release event where artists will complete their work on-site.

Artists are encouraged to develop designs that celebrate the unique character of Taylor and the surrounding region. Proposed artwork should reflect one or more of the following themes: the Taylor Downtown District, the City of Taylor, the Central Texas region, or the State of Texas; local history, culture, architecture, and community identity; or other themes identified for the project.

All artwork must be appropriate for all ages and suitable for a family-friendly public environment. Submissions should avoid obscenities, inappropriate nudity, sexual content or innuendo, depictions of drug or alcohol abuse, horror elements, racism, violence, or any imagery that degrades individuals or groups. Artwork should also avoid profanity, blasphemy, gang-related imagery, or the desecration of cultural symbols.

Artists may choose to complete their piano entirely on-site during the public release event or complete portions of the work in advance. There is no requirement to pre-paint off-site; however, all pianos must be fully completed by the conclusion of the event.

This project offers an opportunity to contribute to Taylor's public spaces while showcasing artistic talent in a highly visible and engaging way.

Name: _____

Organization Name: _____

Mailing Address: _____

Phone: _____ Cell Phone: _____

Email Address: _____

Checklist for Main Street Grant Application

Complete applications, including all required documentation, will be submitted to the Public Arts Advisory Board and Taylor Arts Council Subcommittee

- Application filled in entirely and signed
- Attach W-9
- Attach Proposed Standing Piano Art Work
- Attach proposal including expected materials

Taylor Public Arts Indemnification and Art Release



Artist Rights Release Agreement – Painted Piano Project

By participating in the City of Taylor Painted Piano Project, the undersigned Artist agrees to the following:

The Artist acknowledges that the painted piano, including all artwork applied to it, is created for public display as part of a City-sponsored initiative. Upon completion, the Artist hereby grants and assigns to the City of Taylor full ownership of the physical piano and the artwork embodied on it. The Artist further grants the City of Taylor a perpetual, irrevocable, royalty-free license to use, reproduce, photograph, display, distribute, and promote images of the painted piano and artwork in any media, including but not limited to print, digital, social media, and promotional materials, without further consent or compensation. The Artist waives any claims to future compensation, royalties, or rights of removal once the piano has been installed. The City reserves the right to relocate, maintain, repair, modify, or remove the piano at its sole discretion. The Artist affirms that the submitted design is original and does not infringe upon the rights of any third party. The Artist agrees to indemnify and hold harmless the City of Taylor from any claims arising from copyright or intellectual property disputes.

HOLD HARMLESS AGREEMENT: In consideration of the acceptance of the right to participate, by execution of this entry form. I hereby release and discharge the City of Taylor, and all other sponsors and/or affiliates of the City of Taylor and their officers, employees, directors, agents and representatives and anyone else connected with the management, promotion or presentation of the City of Taylor from any and all known or unknown damages, injuries or losses, judgments and /or claims from any cause that may be suffered by any entrant, participant to his or her person or property. Further, each entrant expressly agrees to indemnify all the foregoing entities, firms, persons and bodies from any and all liability occasioning, occurring or resulting from the conduct of any entrant, participant or spectators assisting or cooperating with entrant under the direction or control of entrant. Further, I agree that any photos or videos of myself or my property as a result of this event may be used promotionally or for sale.

By signing below, the Artist acknowledges and agrees to the terms outlined above.

Agreed: _____ Date: _____

Name (Printed): _____

Taylor Public Arts

Art Guidelines



A. The Taylor Public Arts Advisory Board will provide \$750 to pay artists for projects that meet standards recommended by the Public Arts Advisory Board and adopted by the City Council.

B. The applicant must be able to show examples of work that prove that the artist or organization is able to complete a project of appropriate scale in the time provided.

C. Durability (quality of materials) shall be required in a successful proposal.

D. Subject matter of the project should be timeless. The chosen artist shall consider the local setting and weigh the long-term impact that the work will have on the immediate environment. Artists should try to incorporate existing elements on or around the chosen site.

E. Subject matter shall portray or celebrate one or more of the following themes:

1. The Taylor Downtown District; the City of Taylor, Texas; the Central Texas Region, or the State of Texas.
2. Local history, cultures, character, architecture, or uniqueness.
3. Other themes as identified on a project-by-project basis - Piano Project: Music,

F. Art work shall be appropriate for all ages and family friendly. The following shall be avoided: obscenities, inappropriate nudity, sexual acts or innuendo, depictions of drug and alcohol abuse, horror, racism, degradation of individuals or groups, violence, desecration of cultural symbols, blasphemy, profanity, sexism, and gang related art.

G. Proposals for public art projects shall include conceptual examples, and a statement appropriately explaining imagery use, meaning and inspirational sources.

Taylor Public Arts

Proposal + Materiality



Materiality: _____

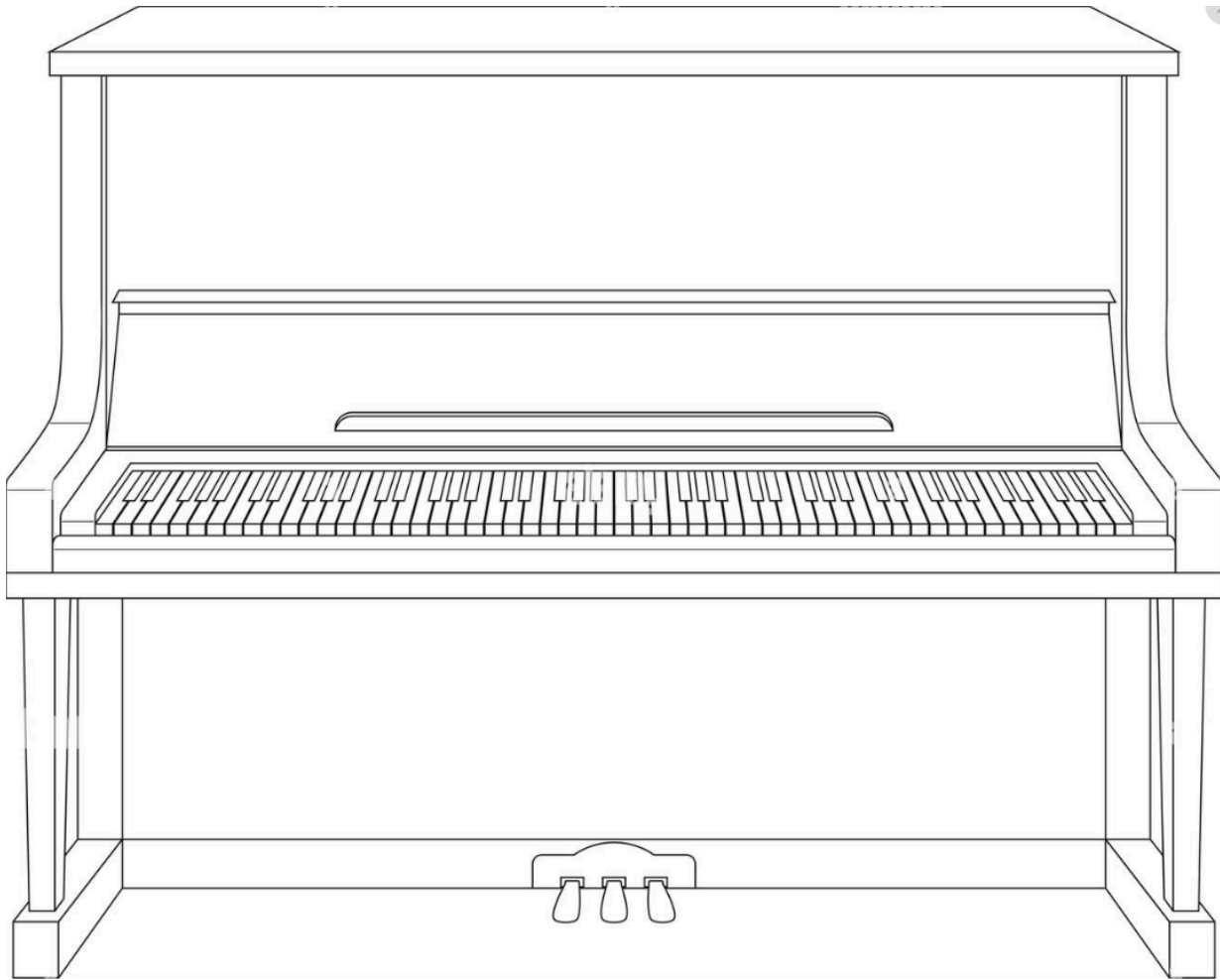

Artist's Statement Regarding Piece: _____

Taylor Public Arts

Example Upright Piano

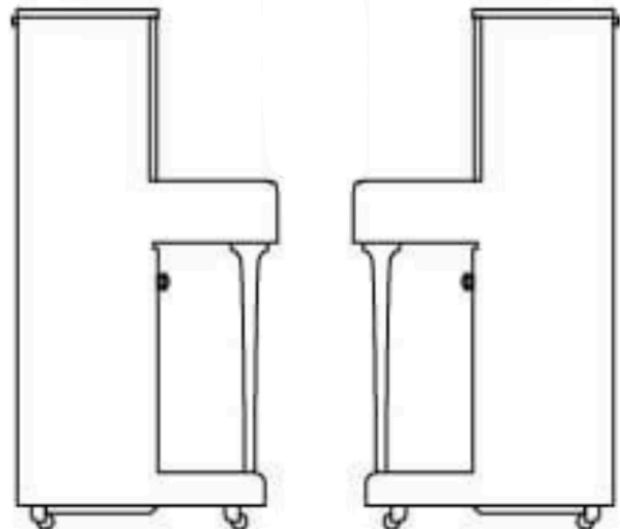
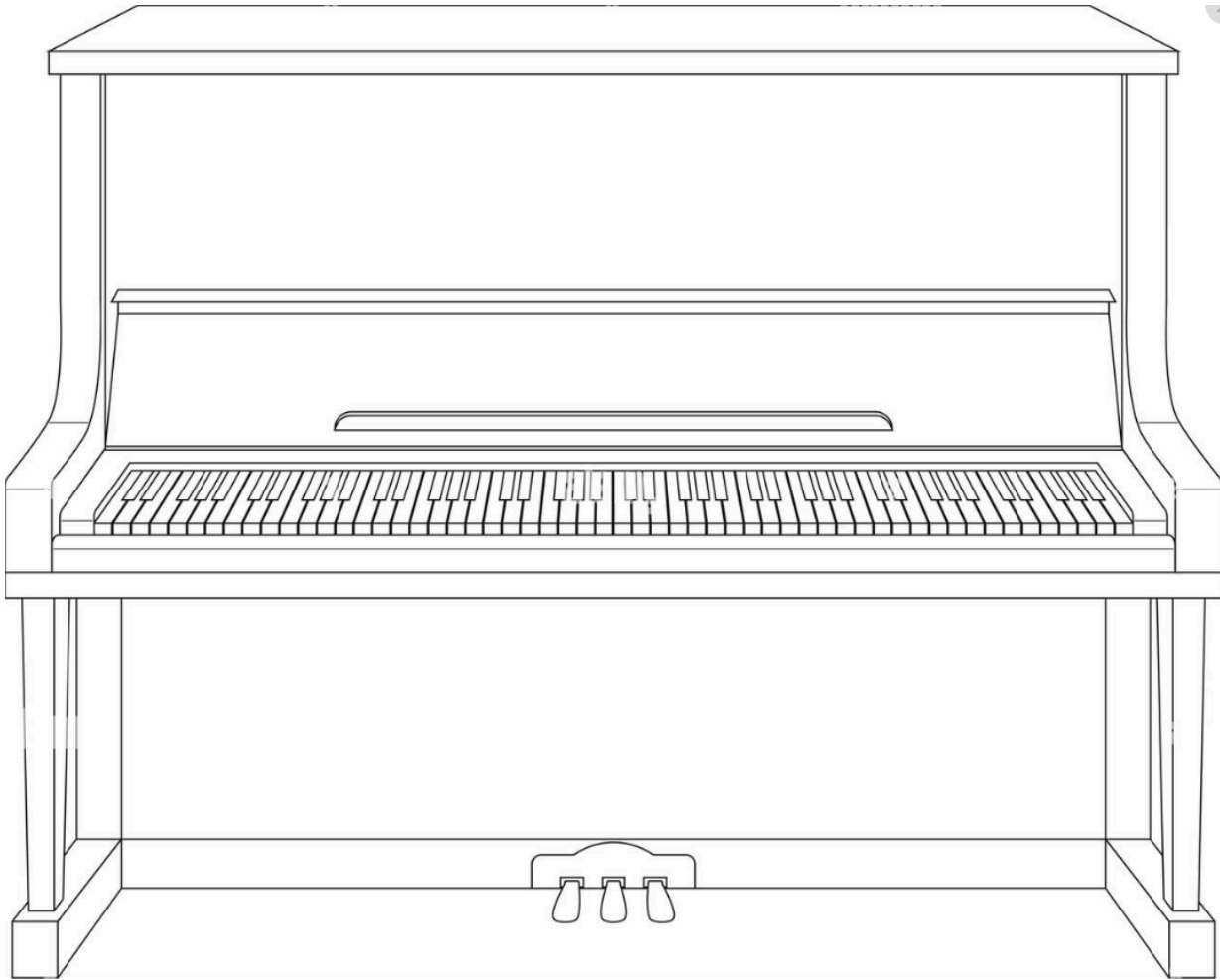

Taylor Public Arts Painted Piano Project



Join us for the Painted Piano Front Porch Release Party, where art and music come to life in downtown Taylor. Watch local artists finish their one-of-a-kind pianos and enjoy a fun, family-friendly celebration of creativity.

PAINTED PIANO EASEMENT AGREEMENT

CITY OF TAYLOR, TEXAS – PUBLIC ARTS ADVISORY BOARD

This Painted Piano Easement Agreement (“Agreement”) is made between:

Grantor (Property Owner): _____ and Grantee: City of Taylor, Texas, acting through the Taylor Public Arts Advisory Board (“City”)

1. Purpose

The purpose of this Agreement is to allow the City to place, display, and maintain a painted piano as part of the Taylor Public Arts Advisory Board’s Painted Piano Project on property owned by the Grantor.

2. Easement Grant

Grantor hereby grants to the City a non-exclusive easement over and across a portion of the property located at:

Property Address: _____

The easement area shall consist solely of the footprint occupied by the painted piano and any immediately necessary clearance for public interaction and maintenance (“Easement Area”).

3. Term

This Agreement shall have a term of three (3) years, beginning on the date of final execution.

4. Rights of the City

The City shall have the right to:

- Place and install a painted piano within the Easement Area
- Allow public interaction with the piano
- Maintain, repair, or remove the piano as needed
- Apply protective coatings or minor improvements to preserve the artwork
- Access the Easement Area at reasonable times for the above purposes

5. Responsibilities of the Grantor

Grantor agrees to:

- Allow unobstructed access to the Easement Area
- Not relocate, alter, damage, or remove the piano
- Notify the City of any damage, safety concerns, or issues affecting the piano
- Maintain the surrounding property in a reasonably safe condition

6. Ownership

The painted piano and all associated artwork shall remain the property of the City unless otherwise agreed in writing.

PAINTED PIANO EASEMENT AGREEMENT

CITY OF TAYLOR, TEXAS – PUBLIC ARTS ADVISORY BOARD

7. Liability

- The City shall be responsible for the installation and general condition of the piano.
- Grantor shall not be responsible for damage to the piano caused by public use, vandalism, or normal wear.
- Each party agrees to be responsible for its own acts and omissions in accordance with applicable Texas law.

8. Maintenance and Condition

The City may, at its discretion:

- Perform maintenance or repairs
- Remove the piano if it becomes unsafe, damaged beyond repair, or inconsistent with program goals

9. Termination

This Agreement may be terminated:

By either party with 30 days written notice

Immediately if the piano poses a safety hazard

Upon termination, the City shall remove the piano within a reasonable timeframe and restore the Easement Area to a condition reasonably similar to its prior state, excluding normal wear.

10. No Transfer of Ownership Interest

This Agreement grants only a limited easement and does not convey any ownership interest in the real property.

11. Entire Agreement

This document constitutes the entire agreement between the parties and may only be amended in writing signed by both parties.

12. Execution

GRANTOR (Property Owner):

Signature: _____

Name: _____

Date: _____

CITY OF TAYLOR, TEXAS:

By: _____

Title: _____

Date: _____



Taylor Public Arts Heritage Square Signature Project

GOALS:

- Addition of Sesquicentennial Art Piece in Heritage Square - on the Wall Facing the Picnic Tables (38ft x 12 ft) (Estimated Mosaic Cost: \$20,520)
- Addition of Signature Art Piece on back of Heritage Square Stage (33ft by 9.5 ft) (Estimated Mosaic Cost: \$14,107.50)

BUDGET/Funding Sources

- Contribution from TIF Fund

Timeline

Phase 1: Artist Selection (6–8 weeks)

- Release Call for Artists (3–4 weeks open)
- Review submissions and shortlist finalists
- Conduct interviews (if applicable)
- Final artist selection and approval by board/council (if required)

Phase 2: Design Development (4–6 weeks)

- Artist develops concept proposal(s)
- Internal review (staff, advisory board, stakeholders)
- Community input opportunity (optional but recommended)
- Final design approval
- Execute artist contract

Phase 3: Pre-Installation (3–5 weeks)

- Site preparation (cleaning, priming, repairs)
- Permitting
- Schedule installation dates and logistics

Phase 4: Installation (1–4 weeks)

- Mural: typically 1–2 weeks
- Mosaic: typically 2–4+ weeks depending on complexity
- Public engagement opportunities (optional: live painting days, volunteer components)

Phase 6: Finishing (1–2 weeks)

- Sealing and protective coatings
- Final inspection and punch list completion
- Documentation (photos, artist statement, project summary)

Phase 7: Dedication & Promotion (2–3 weeks planning)

- Plan unveiling event at Heritage Square
- Coordinate signage/interpretive plaque
- Marketing and communications rollout (press release, social media, partners)
- Host ribbon cutting or community celebration

Artist Application

The City of Taylor invites artists to submit qualifications and proposals for a two-part public art opportunity in Heritage Square. This project will introduce highly visible, permanent installations designed to celebrate the community's identity, history, and sense of place while enhancing one of Taylor's most active public gathering spaces.

Artists are asked to develop cohesive or complementary designs for the following project components:

Sesquicentennial Art Piece

- Wall facing the picnic tables (38 ft x 12 ft)
- Estimated Mosaic Cost: \$20,520
- This installation should commemorate the City of Taylor's 150-year history and incorporate the Sesquicentennial Logo

Signature Art Piece (Back of Stage)

- Back wall of the Heritage Square Stage (33 ft x 9.5 ft)
- Estimated Mosaic Cost: \$14,107.50
- This work will act as a dynamic visual backdrop for performances and events, contributing to the overall atmosphere and identity of Heritage Square.

Artists are encouraged to create designs that celebrate the unique character of Taylor and the surrounding region. Proposed artwork should reflect one or more of the following themes: the Taylor Downtown District; the City of Taylor; the Central Texas region; or the State of Texas. Submissions may also draw from local history, culture, architecture, and community identity, or present other concepts that demonstrate a strong and thoughtful connection to the site.

All artwork must be appropriate for all ages and suitable for a family-friendly public environment. Submissions must not include obscenities, nudity, sexual content or innuendo, depictions of drug or alcohol abuse, horror imagery, racism, violence, or any content that degrades individuals or groups. Artwork should also avoid profanity, blasphemy, gang-related imagery, or the desecration of cultural or historical symbols.

Submissions should demonstrate artistic excellence, feasibility within the proposed budget, and durability for long-term outdoor display. Artists should also consider how the two installations may visually relate to one another and contribute to a cohesive experience within Heritage Square.

Checklist for Proposal

Complete applications, including all required documentation, will be submitted to the Public Arts Advisory Board and Taylor Arts Council Subcommittee

- Application filled in entirely and signed
- Attach W-9
- Attach Proposed Art work for both areas and renderings
- Attach proposal including expected materials

Name: _____

Organization Name: _____

Mailing Address: _____

Phone: _____ Cell Phone: _____

Email Address: _____

Artist Rights Release Agreement – Heritage Square Signature Project

By participating in the City of Taylor Heritage Square Signature Project, the undersigned Artist agrees to the following:

The Artist acknowledges that the painted piano, including all artwork applied to it, is created for public display as part of a City-sponsored initiative. Upon completion, the Artist hereby grants and assigns to the City of Taylor full ownership of the physical piano and the artwork embodied on it. The Artist further grants the City of Taylor a perpetual, irrevocable, royalty-free license to use, reproduce, photograph, display, distribute, and promote images of the painted piano and artwork in any media, including but not limited to print, digital, social media, and promotional materials, without further consent or compensation. The Artist waives any claims to future compensation, royalties, or rights of removal once the piano has been installed. The City reserves the right to relocate, maintain, repair, modify, or remove the piano at its sole discretion. The Artist affirms that the submitted design is original and does not infringe upon the rights of any third party. The Artist agrees to indemnify and hold harmless the City of Taylor from any claims arising from copyright or intellectual property disputes.

HOLD HARMLESS AGREEMENT: In consideration of the acceptance of the right to participate, by execution of this entry form. I hereby release and discharge the City of Taylor, and all other sponsors and/or affiliates of the City of Taylor and their officers, employees, directors, agents and representatives and anyone else connected with the management, promotion or presentation of the City of Taylor from any and all known or unknown damages, injuries or losses, judgments and /or claims from any cause that may be suffered by any entrant, participant to his or her person or property. Further, each entrant expressly agrees to indemnify all the foregoing entities, firms, persons and bodies from any and all liability occasioning, occurring or resulting from the conduct of any entrant, participant or spectators assisting or cooperating with entrant under the direction or control of entrant. Further, I agree that any photos or videos of myself or my property as a result of this event may be used promotionally or for sale.

By signing below, the Artist acknowledges and agrees to the terms outlined above.

Agreed: _____ Date: _____

Name (Printed): _____

Taylor Public Arts

Art Guidelines



A. The Taylor Public Arts Advisory Board will provide pay to artists for projects that meet standards recommended by the Public Arts Advisory Board and adopted by the City Council.

B. The applicant must be able to show examples of work that prove that the artist or organization is able to complete a project of appropriate scale in the time provided.

C. Durability (quality of materials) shall be required in a successful proposal.

D. Subject matter of the project should be timeless. The chosen artist shall consider the local setting and weigh the long-term impact that the work will have on the immediate environment. Artists should try to incorporate existing elements on or around the chosen site.

E. Subject matter shall portray or celebrate one or more of the following themes:

1. The Taylor Downtown District; the City of Taylor, Texas; the Central Texas Region, or the State of Texas.
2. Local history, cultures, character, architecture, or uniqueness.
3. Other themes as identified on a project-by-project basis - Piano Project: Music,

F. Art work shall be appropriate for all ages and family friendly. The following shall be avoided: obscenities, inappropriate nudity, sexual acts or innuendo, depictions of drug and alcohol abuse, horror, racism, degradation of individuals or groups, violence, desecration of cultural symbols, blasphemy, profanity, sexism, and gang related art.

G. Proposals for public art projects shall include conceptual examples, and a statement appropriately explaining imagery use, meaning and inspirational sources.