

**AGENDA**  
**CITY OF TAYLOR, TEXAS**  
**PUBLIC ARTS ADVISORY BOARD MEETING**  
**CITY HALL CONFERENCE ROOM, 400 PORTER STREET, TAYLOR, TX 76574**  
**MARCH 25, 2026, 5:30 PM**

- I. CALL TO ORDER AND DECLARE A QUORUM
- II. CITIZEN COMMUNICATION
- III. CONSENT AGENDA
  - 1. Approve minutes from the February 25, 2026 meeting of the Public Arts Advisory Board
- IV. REGULAR AGENDA - NEW BUSINESS
  - 2. Discuss and take action on the appointment of the Chair position
  - 3. Discuss and take action on the appointment of the Vice-Chair position
- V. REGULAR AGENDA - CONTINUING BUSINESS
  - 4. Consider and take potential action on the Painted Piano Project proposal.
  - 5. Consider and take potential action on the Heritage Square Signature Art Project
  - 6. Receive an update on Robinson Park Portals - Texas Geochaching Association Murals
  - 7. Receive update and take potential action from Music on Main Committee.
- VI. ADJOURN

The Board or Commission may vote and/or act upon each of the items listed in this Agenda. The Board or Commission reserves the right to retire into executive session concerning any of the items listed on this Agenda, whenever it is considered necessary and legally justified under the Open Meetings Act, I certify that the notice of meeting was posted in the Taylor City Hall Lobby before 5:30 pm on March 19, 2026 and remained posted for at least three business days before the scheduled date of said meeting.

Ruby Fisher

Special Events Coordinator

Date: 03/19/2026

# MINUTES

## CITY OF TAYLOR, TEXAS

### PUBLIC ARTS ADVISORY BOARD MEETING

City Hall – Council Chambers 400 Porter Street, Taylor, Texas 76574

February 25, 2026, 5:30 p.m.

#### MEMBERS PRESENT

Bryan Richie  
Monica Zavala  
Gail Samuels  
Betsy Askew  
Nicolas Nadeau

#### MEMBERS ABSENT

Cindy Chapter

#### OTHERS PRESENT

Ruby Fisher, City Liaison  
Greg Redden,  
Councilmember  
Heather Long, Council  
Member  
Niecy Baum, Downtown  
Director

I. CALL TO ORDER AND DECLARE A QUORUM – A quorum was declared, and a meeting was called to order at 5:33 pm

II. PUBLIC COMMENT

III. CONSENT AGENDA

1. Approve the Minutes of the Public Arts Advisory Board meeting on January 14, 2026.
  - a. A motion was made to approve the minutes as presented by Bryan Richie, seconded by Monica Zavala – passed unanimously.

IV. REGULAR AGENDA – NEW BUSINESS

2. Introduce new Board Members.
  - a. Betsy Askew introduced herself – she reported that she applied to be on the PAAB because Ruby Fisher and Bryan Richie reached out to her – she is an artist and wishes to see more art downtown. Bryan Richie commented that Betsy is a part of the Ripple and Rose Café that is the coolest spot in town.
  - b. Nicolas Nadea introduced himself as a small business owner of the Everytime Institute – an art gallery that hosts classes located in Old Taylor High. Nicolas noted that he was passionate about assisting grow the city with art in mind as he is aware of the consequences when growth happens without art.
  - c. The presentation was marked as received.
3. Have discussion and take potential action on the implementation of Taylor Public Arts - Painted Piano Project
  - a. A motion was made to establish a Painted Piano Project subcommittee headed by Nicolas Nadeau by Bryan Richie, seconded by Gail Samuels. The motion passed unanimously.
4. Have discussion and take potential action on the implementation of the 150th/Heritage Square Mural project.
  - a. A motion was made to establish a Heritage Square Mural Sub Committee headed by Bryan Richie, supported by Betsy Askew by Gail Samuels, seconded by Monica Zavala. Passed unanimously.

IV. REGULAR AGENDA - CONTINUING BUSINESS:

5. Review and provide potential approval of Proposed Portal Murals from the Texas Geocachers Association.
    - a. A motion was to provide a recommendation of approval for the proposed Portal Murals from the Texas Geocachers Association by Bryan Richie, seconded by Nicolas Nadeau. Passed unanimously.
  6. Review and provide potential approval of Music on Main Posters for the Spring 2026 season.
    - a. A motion was made to provide a recommendation of approval for the Music on Main Poster for the Spring 2026 Season by Monica Zavala, seconded by Betsy Askew. Passed unanimously.
- VI. ADJOURN – A motion was made to adjourn at 6:27 pm by Bryan Richie, seconded by Nicolas Nadea. Passed unanimously.



# Taylor Public Arts

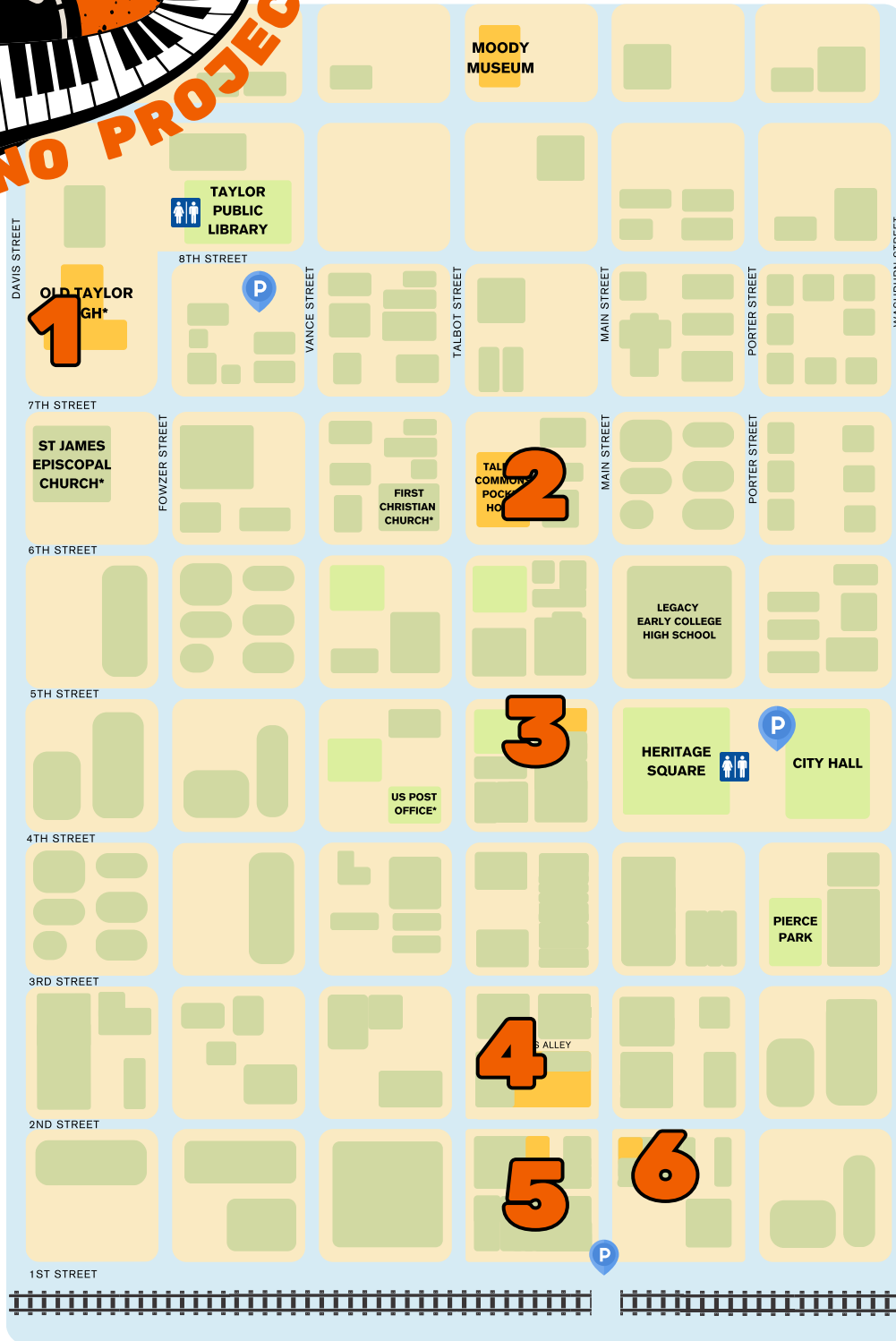

- 1. Old Taylor High - HOT Tax Funded
- 2. Talbot Commons Pocket Hotel - Privately Funded
- 3. Karch Music - TIF Funded
- 4. McCrory Timmerman - TIF Funded

- 5. Black Sparrow Music Parlor - TIF Funded
- 6. 2<sup>nd</sup> and Main Building - TIF Funded
- 7. Percussion Park - HOT Tax Funded and Non-profit Funded

# Taylor Public Arts

## BUDGET/Funding Sources

- \$750.00/artist \* 7 pianos - \$5250.00
- \$175 for tuning - \$1,225
- Piano Dolly Materials?
- Locks - \$140
- Hasps - \$70
- Marketing - \$300
- Front Porch Party - Piano Release: \$1,000.00

Total Cost: \$8,500

- TIF Fund for Public Art: \$6,650.00
- HOT Tax Request: \$1,850.00

## IMPLEMENTATION TIMELINE

Painted Piano Project Implementation Timeline (Post-Council Approval)

Week 0 – Council Approval

- Formal approval granted
- Budget and scope confirmed
- Internal project lead assigned
- Finalize project guidelines

Weeks 1–2 – Artist Call & Promotion

- Release Call for Artists
- Promote through city channels, social media, and local arts networks
- Conduct outreach to schools, artists, and community groups

Weeks 3–7 – Application Period

- Accept submissions (typically 2–3 weeks)
- Respond to inquiries and provide clarifications
- Begin preliminary review as applications are received

Week 7 – Selection Process

- Convene selection committee
- Review and score submissions
- Notify selected artists and alternates

Weeks 8–9 – Logistics & Preparation

- Procure or accept donated pianos
- Coordinate piano tuning and minor repairs (if needed)
- Distribute stipends to artists
- Finalize installation plan and site permissions



Weeks 10–12 – Painting Phase

- Artists paint pianos (on-site or designated workspace)
- Monitor progress and ensure adherence to guidelines

Week 13 – Installation

- Transport and secure pianos at designated locations
- Install signage (artist credit, project info, rules for use)
- Final inspection for safety and quality

Week 14 – Launch & Activation

- Host Porch Piano Release Party
- Promote via press release and social media
- Encourage community engagement (photos, performances, etc.)

Ongoing – Maintenance & Program Management

- Routine inspections and touch-ups as needed
- Monitor for vandalism or weather damage
- Plan for seasonal rotation or long-term storage if applicable
- Ensure Painted Piano Location are on directory guide

Optional (6–12 Months Post-Launch) – Program Evaluation

- Gather community feedback
- Assess impact and participation
- Determine continuation, expansion, or improvements

# Taylor Public Arts Painted Piano Project



We're looking for creative minds to transform pianos into public works of art! Your design could bring music, color, and joy to Taylor's public spaces.

Make your mark in historic downtown Taylor!

 Let your art be heard and seen!



# Taylor Public Arts

## Artist Application



The City of Taylor invites artists to participate in the Painted Piano Project, a public art initiative designed to bring creativity, culture, and community engagement to the downtown district. Selected artists will transform donated pianos into vibrant, functional works of art that reflect the spirit and identity of Taylor. Completed pianos will be installed throughout the community in August 2026, culminating in a public release event where artists will complete their work on-site.

Artists are encouraged to develop designs that celebrate the unique character of Taylor and the surrounding region. Proposed artwork should reflect one or more of the following themes: the Taylor Downtown District, the City of Taylor, the Central Texas region, or the State of Texas; local history, culture, architecture, and community identity; or other themes identified for the project.

All artwork must be appropriate for all ages and suitable for a family-friendly public environment. Submissions should avoid obscenities, inappropriate nudity, sexual content or innuendo, depictions of drug or alcohol abuse, horror elements, racism, violence, or any imagery that degrades individuals or groups. Artwork should also avoid profanity, blasphemy, gang-related imagery, or the desecration of cultural symbols.

Artists may choose to complete their piano entirely on-site during the public release event or complete portions of the work in advance. There is no requirement to pre-paint off-site; however, all pianos must be fully completed by the conclusion of the event.

This project offers an opportunity to contribute to Taylor's public spaces while showcasing artistic talent in a highly visible and engaging way.

Name: \_\_\_\_\_

Organization Name: \_\_\_\_\_

Mailing Address: \_\_\_\_\_

Phone: \_\_\_\_\_ Cell Phone: \_\_\_\_\_

Email Address: \_\_\_\_\_

## Checklist for Main Street Grant Application

Complete applications, including all required documentation, will be submitted to the Public Arts Advisory Board and Taylor Arts Council Subcommittee

- Application filled in entirely and signed
- Attach W-9
- Attach Proposed Standing Piano Art Work
- Attach proposal including expected materials

# Taylor Public Arts Indemnification and Art Release



Artist Rights Release Agreement – Painted Piano Project

By participating in the City of Taylor Painted Piano Project, the undersigned Artist agrees to the following:

The Artist acknowledges that the painted piano, including all artwork applied to it, is created for public display as part of a City-sponsored initiative. Upon completion, the Artist hereby grants and assigns to the City of Taylor full ownership of the physical piano and the artwork embodied on it. The Artist further grants the City of Taylor a perpetual, irrevocable, royalty-free license to use, reproduce, photograph, display, distribute, and promote images of the painted piano and artwork in any media, including but not limited to print, digital, social media, and promotional materials, without further consent or compensation. The Artist waives any claims to future compensation, royalties, or rights of removal once the piano has been installed. The City reserves the right to relocate, maintain, repair, modify, or remove the piano at its sole discretion. The Artist affirms that the submitted design is original and does not infringe upon the rights of any third party. The Artist agrees to indemnify and hold harmless the City of Taylor from any claims arising from copyright or intellectual property disputes.

**HOLD HARMLESS AGREEMENT:** In consideration of the acceptance of the right to participate, by execution of this entry form. I hereby release and discharge the City of Taylor, and all other sponsors and/or affiliates of the City of Taylor and their officers, employees, directors, agents and representatives and anyone else connected with the management, promotion or presentation of the City of Taylor from any and all known or unknown damages, injuries or losses, judgments and /or claims from any cause that may be suffered by any entrant, participant to his or her person or property. Further, each entrant expressly agrees to indemnify all the foregoing entities, firms, persons and bodies from any and all liability occasioning, occurring or resulting from the conduct of any entrant, participant or spectators assisting or cooperating with entrant under the direction or control of entrant. Further, I agree that any photos or videos of myself or my property as a result of this event may be used promotionally or for sale.

By signing below, the Artist acknowledges and agrees to the terms outlined above.

Agreed: \_\_\_\_\_ Date: \_\_\_\_\_

Name (Printed): \_\_\_\_\_

# Taylor Public Arts

## Art Guidelines



A. The Taylor Public Arts Advisory Board will provide \$750 to pay artists for projects that meet standards recommended by the Public Arts Advisory Board and adopted by the City Council.

B. The applicant must be able to show examples of work that prove that the artist or organization is able to complete a project of appropriate scale in the time provided.

C. Durability (quality of materials) shall be required in a successful proposal.

D. Subject matter of the project should be timeless. The chosen artist shall consider the local setting and weigh the long-term impact that the work will have on the immediate environment. Artists should try to incorporate existing elements on or around the chosen site.

E. Subject matter shall portray or celebrate one or more of the following themes:

1. The Taylor Downtown District; the City of Taylor, Texas; the Central Texas Region, or the State of Texas.
2. Local history, cultures, character, architecture, or uniqueness.
3. Other themes as identified on a project-by-project basis - Piano Project: Music,

F. Art work shall be appropriate for all ages and family friendly. The following shall be avoided: obscenities, inappropriate nudity, sexual acts or innuendo, depictions of drug and alcohol abuse, horror, racism, degradation of individuals or groups, violence, desecration of cultural symbols, blasphemy, profanity, sexism, and gang related art.

G. Proposals for public art projects shall include conceptual examples, and a statement appropriately explaining imagery use, meaning and inspirational sources.

# Taylor Public Arts

## Proposal + Materiality



Materiality: \_\_\_\_\_  
\_\_\_\_\_  
\_\_\_\_\_

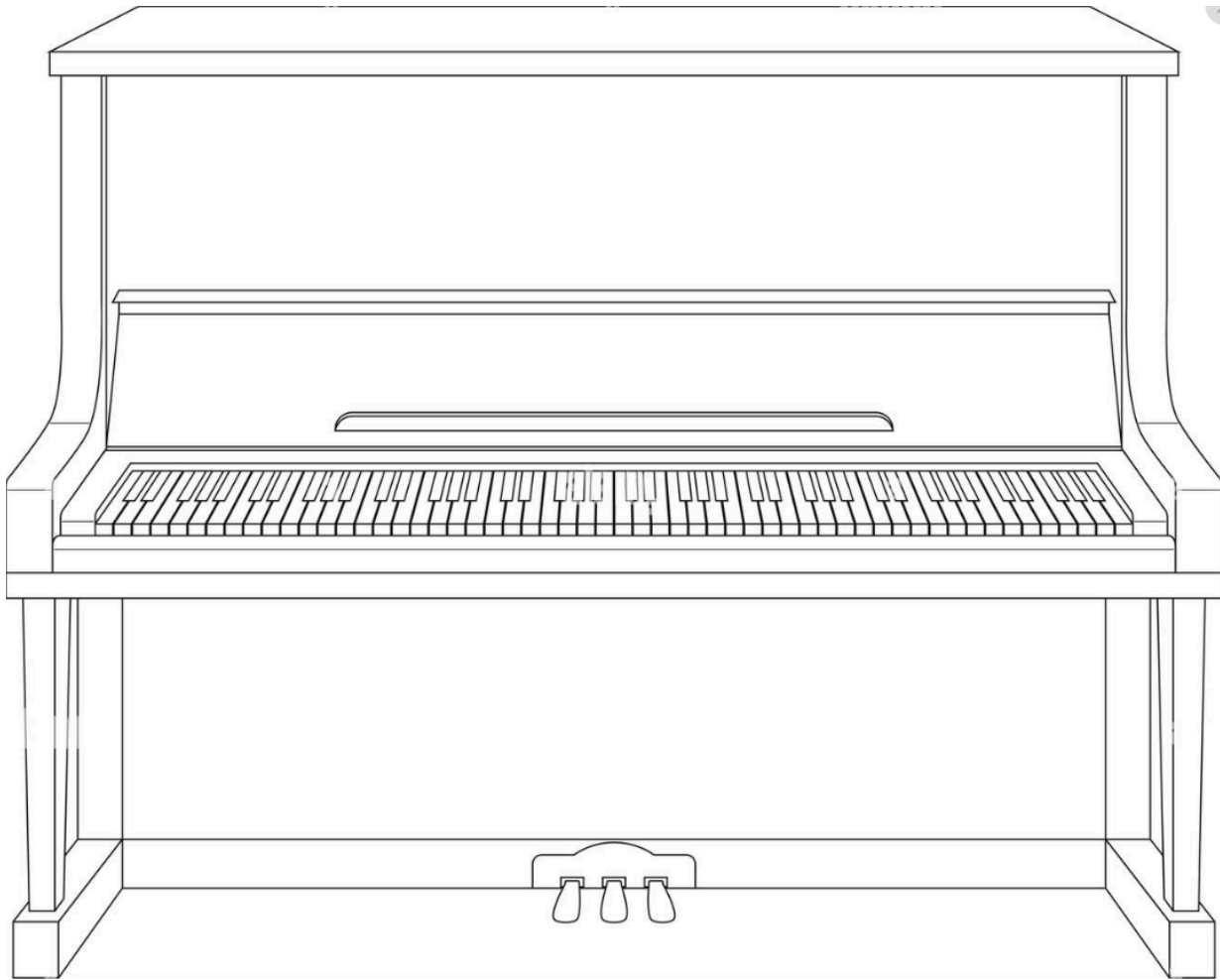

Artist's Statement Regarding Piece: \_\_\_\_\_  
\_\_\_\_\_  
\_\_\_\_\_  
\_\_\_\_\_  
\_\_\_\_\_

# Taylor Public Arts

## Example Upright Piano

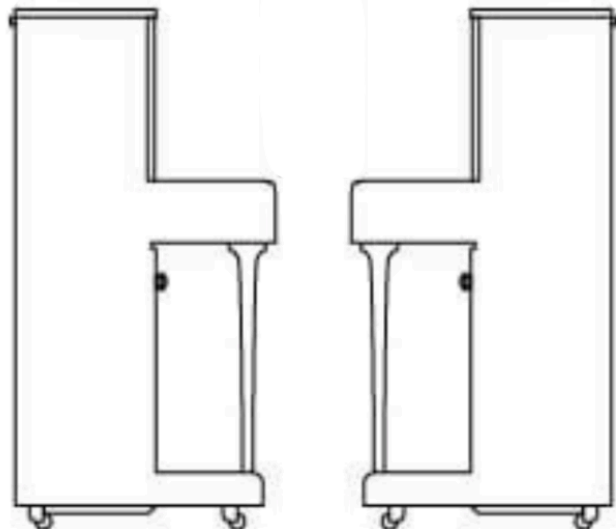
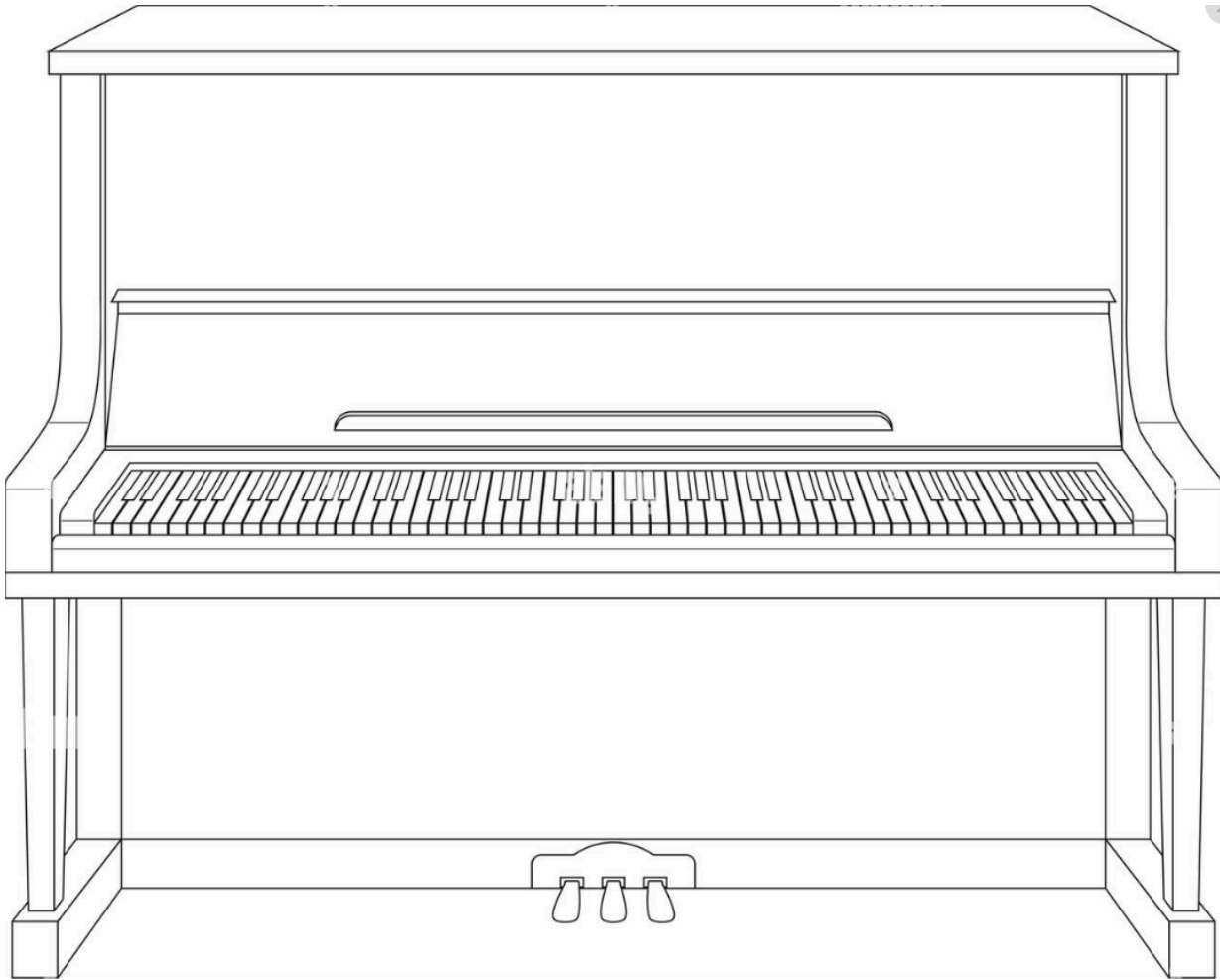

# Taylor Public Arts Painted Piano Project



**Join us for the Painted Piano Front Porch Release Party, where art and music come to life in downtown Taylor. Watch local artists finish their one-of-a-kind pianos and enjoy a fun, family-friendly celebration of creativity.**

# **PAINTED PIANO EASEMENT AGREEMENT**

## **CITY OF TAYLOR, TEXAS – PUBLIC ARTS ADVISORY BOARD**

This Painted Piano Easement Agreement (“Agreement”) is made between:

Grantor (Property Owner): \_\_\_\_\_ and Grantee: City of Taylor, Texas, acting through the Taylor Public Arts Advisory Board (“City”)

### **1. Purpose**

The purpose of this Agreement is to allow the City to place, display, and maintain a painted piano as part of the Taylor Public Arts Advisory Board’s Painted Piano Project on property owned by the Grantor.

### **2. Easement Grant**

Grantor hereby grants to the City a non-exclusive easement over and across a portion of the property located at:

Property Address: \_\_\_\_\_

The easement area shall consist solely of the footprint occupied by the painted piano and any immediately necessary clearance for public interaction and maintenance (“Easement Area”).

### **3. Term**

This Agreement shall have a term of three (3) years, beginning on the date of final execution.

### **4. Rights of the City**

The City shall have the right to:

- Place and install a painted piano within the Easement Area
- Allow public interaction with the piano
- Maintain, repair, or remove the piano as needed
- Apply protective coatings or minor improvements to preserve the artwork
- Access the Easement Area at reasonable times for the above purposes

### **5. Responsibilities of the Grantor**

Grantor agrees to:

- Allow unobstructed access to the Easement Area
- Not relocate, alter, damage, or remove the piano
- Notify the City of any damage, safety concerns, or issues affecting the piano
- Maintain the surrounding property in a reasonably safe condition

### **6. Ownership**

The painted piano and all associated artwork shall remain the property of the City unless otherwise agreed in writing.

# PAINTED PIANO EASEMENT AGREEMENT

## CITY OF TAYLOR, TEXAS – PUBLIC ARTS ADVISORY BOARD

### 7. Liability

- The City shall be responsible for the installation and general condition of the piano.
- Grantor shall not be responsible for damage to the piano caused by public use, vandalism, or normal wear.
- Each party agrees to be responsible for its own acts and omissions in accordance with applicable Texas law.

### 8. Maintenance and Condition

The City may, at its discretion:

- Perform maintenance or repairs
- Remove the piano if it becomes unsafe, damaged beyond repair, or inconsistent with program goals

### 9. Termination

This Agreement may be terminated:

By either party with 30 days written notice

Immediately if the piano poses a safety hazard

Upon termination, the City shall remove the piano within a reasonable timeframe and restore the Easement Area to a condition reasonably similar to its prior state, excluding normal wear.

### 10. No Transfer of Ownership Interest

This Agreement grants only a limited easement and does not convey any ownership interest in the real property.

### 11. Entire Agreement

This document constitutes the entire agreement between the parties and may only be amended in writing signed by both parties.

### 12. Execution

GRANTOR (Property Owner):

Signature: \_\_\_\_\_

Name: \_\_\_\_\_

Date: \_\_\_\_\_

CITY OF TAYLOR, TEXAS:

By: \_\_\_\_\_

Title: \_\_\_\_\_

Date: \_\_\_\_\_



# Taylor Public Arts Heritage Square Signature Project

## GOALS:

- Addition of Sesquicentennial Art Piece in Heritage Square - on the Wall Facing the Picnic Tables (38ft x 12 ft) (Estimated Mosaic Cost: \$20,520)
- Addition of Signature Art Piece on back of Heritage Square Stage (33ft by 9.5 ft) (Estimated Mosaic Cost: \$14,107.50)

## BUDGET/Funding Sources

- Contribution from TIF Fund

## Timeline

### Phase 1: Artist Selection (6–8 weeks)

- Release Call for Artists (3–4 weeks open)
- Review submissions and shortlist finalists
- Conduct interviews (if applicable)
- Final artist selection and approval by board/council (if required)

### Phase 2: Design Development (4–6 weeks)

- Artist develops concept proposal(s)
- Internal review (staff, advisory board, stakeholders)
- Community input opportunity (optional but recommended)
- Final design approval
- Execute artist contract

### Phase 3: Pre-Installation (3–5 weeks)

- Site preparation (cleaning, priming, repairs)
- Permitting
- Schedule installation dates and logistics

### Phase 4: Installation (1–4 weeks)

- Mural: typically 1–2 weeks
- Mosaic: typically 2–4+ weeks depending on complexity
- Public engagement opportunities (optional: live painting days, volunteer components)

### Phase 6: Finishing (1–2 weeks)

- Sealing and protective coatings
- Final inspection and punch list completion
- Documentation (photos, artist statement, project summary)

### Phase 7: Dedication & Promotion (2–3 weeks planning)

- Plan unveiling event at Heritage Square
- Coordinate signage/interpretive plaque
- Marketing and communications rollout (press release, social media, partners)
- Host ribbon cutting or community celebration

## **Artist Application**

The City of Taylor invites artists to submit qualifications and proposals for a two-part public art opportunity in Heritage Square. This project will introduce highly visible, permanent installations designed to celebrate the community's identity, history, and sense of place while enhancing one of Taylor's most active public gathering spaces.

Artists are asked to develop cohesive or complementary designs for the following project components:

### Sesquicentennial Art Piece

- Wall facing the picnic tables (38 ft x 12 ft)
- Estimated Mosaic Cost: \$20,520
- This installation should commemorate the City of Taylor's 150-year history and incorporate the Sesquicentennial Logo

### Signature Art Piece (Back of Stage)

- Back wall of the Heritage Square Stage (33 ft x 9.5 ft)
- Estimated Mosaic Cost: \$14,107.50
- This work will act as a dynamic visual backdrop for performances and events, contributing to the overall atmosphere and identity of Heritage Square.

Artists are encouraged to create designs that celebrate the unique character of Taylor and the surrounding region. Proposed artwork should reflect one or more of the following themes: the Taylor Downtown District; the City of Taylor; the Central Texas region; or the State of Texas. Submissions may also draw from local history, culture, architecture, and community identity, or present other concepts that demonstrate a strong and thoughtful connection to the site.

All artwork must be appropriate for all ages and suitable for a family-friendly public environment. Submissions must not include obscenities, nudity, sexual content or innuendo, depictions of drug or alcohol abuse, horror imagery, racism, violence, or any content that degrades individuals or groups. Artwork should also avoid profanity, blasphemy, gang-related imagery, or the desecration of cultural or historical symbols.

Submissions should demonstrate artistic excellence, feasibility within the proposed budget, and durability for long-term outdoor display. Artists should also consider how the two installations may visually relate to one another and contribute to a cohesive experience within Heritage Square.

## **Checklist for Proposal**

Complete applications, including all required documentation, will be submitted to the Public Arts Advisory Board and Taylor Arts Council Subcommittee

- Application filled in entirely and signed
- Attach W-9
- Attach Proposed Art work for both areas and renderings
- Attach proposal including expected materials

Name: \_\_\_\_\_

Organization Name: \_\_\_\_\_

Mailing Address: \_\_\_\_\_

Phone: \_\_\_\_\_ Cell Phone: \_\_\_\_\_

Email Address: \_\_\_\_\_

Artist Rights Release Agreement – Heritage Square Signature Project

By participating in the City of Taylor Heritage Square Signature Project, the undersigned Artist agrees to the following:

The Artist acknowledges that the painted piano, including all artwork applied to it, is created for public display as part of a City-sponsored initiative. Upon completion, the Artist hereby grants and assigns to the City of Taylor full ownership of the physical piano and the artwork embodied on it. The Artist further grants the City of Taylor a perpetual, irrevocable, royalty-free license to use, reproduce, photograph, display, distribute, and promote images of the painted piano and artwork in any media, including but not limited to print, digital, social media, and promotional materials, without further consent or compensation. The Artist waives any claims to future compensation, royalties, or rights of removal once the piano has been installed. The City reserves the right to relocate, maintain, repair, modify, or remove the piano at its sole discretion. The Artist affirms that the submitted design is original and does not infringe upon the rights of any third party. The Artist agrees to indemnify and hold harmless the City of Taylor from any claims arising from copyright or intellectual property disputes.

**HOLD HARMLESS AGREEMENT:** In consideration of the acceptance of the right to participate, by execution of this entry form. I hereby release and discharge the City of Taylor, and all other sponsors and/or affiliates of the City of Taylor and their officers, employees, directors, agents and representatives and anyone else connected with the management, promotion or presentation of the City of Taylor from any and all known or unknown damages, injuries or losses, judgments and /or claims from any cause that may be suffered by any entrant, participant to his or her person or property. Further, each entrant expressly agrees to indemnify all the foregoing entities, firms, persons and bodies from any and all liability occasioning, occurring or resulting from the conduct of any entrant, participant or spectators assisting or cooperating with entrant under the direction or control of entrant. Further, I agree that any photos or videos of myself or my property as a result of this event may be used promotionally or for sale.

By signing below, the Artist acknowledges and agrees to the terms outlined above.

Agreed: \_\_\_\_\_ Date: \_\_\_\_\_

Name (Printed): \_\_\_\_\_

# Taylor Public Arts

## Art Guidelines



A. The Taylor Public Arts Advisory Board will provide pay to artists for projects that meet standards recommended by the Public Arts Advisory Board and adopted by the City Council.

B. The applicant must be able to show examples of work that prove that the artist or organization is able to complete a project of appropriate scale in the time provided.

C. Durability (quality of materials) shall be required in a successful proposal.

D. Subject matter of the project should be timeless. The chosen artist shall consider the local setting and weigh the long-term impact that the work will have on the immediate environment. Artists should try to incorporate existing elements on or around the chosen site.

E. Subject matter shall portray or celebrate one or more of the following themes:

1. The Taylor Downtown District; the City of Taylor, Texas; the Central Texas Region, or the State of Texas.
2. Local history, cultures, character, architecture, or uniqueness.
3. Other themes as identified on a project-by-project basis - Piano Project: Music,

F. Art work shall be appropriate for all ages and family friendly. The following shall be avoided: obscenities, inappropriate nudity, sexual acts or innuendo, depictions of drug and alcohol abuse, horror, racism, degradation of individuals or groups, violence, desecration of cultural symbols, blasphemy, profanity, sexism, and gang related art.

G. Proposals for public art projects shall include conceptual examples, and a statement appropriately explaining imagery use, meaning and inspirational sources.



Tony Von Uses L, M, N, O, P



TONY VON



DR JAMES DICKEY

USES M, S, T, U, X, Z

$$U = X + 0$$

$\frac{3}{4}$   $\frac{1}{4}$

TX XZ

# Dr. James L. Dickey



*x pas*

*milpas*